

TPWN "NETWORK" SERIES PALLET TRUCK SCALE



TPWN

Easy to use and handy pallet trucks with integrated electronic weighing, are necessary when one wants to weigh accurately saving time. The large display makes it easy to read in all working conditions. It is fitted with an easily replaceable built-in battery with extractable drawer.

Available also in TRIPLE RANGE model.

MAIN FEATURES

- Maximum lifting capacity: 2000 kg.
- Accuracy: +/- 0.1% of the capacity.
- Fork dimensions 1170 x 550 x 85 mm.
- Weighs about 120 kg.
- Structure in extra thick steel and oven-fire painted mechanics.
- Steering wheels and double loading rollers with a poliurethane coating.
- 4 shear-beam load cells.
- Weight indicator with large LCD 25mm display high contrast digits, which are clearly visible even in poor lighting conditions, and waterproof membrane keyboard, with 4 functional keys.
- Configuration, calibration and diagnostics from PC with LCSTOOL utility.
- Fitted with extractable drawer containing 4 AA batteries.
- The operating time is of about 80 hours of continuous use or three months with the typical non continuous use, thanks to its auto switch-off function.
- Programmable auto power saving function.
- Battery level indication.
- Triple graduation (TPWN3 model) for more precision about the smaller weights, maintaining a great capacity of loading.

SELECTABLE FUNCTIONS

- **High Resolution Weighing x 10**
- **Net/Gross**
- **PEAK** (maximum detected value)
- **Totalization**
- **HOLD** (lock of displayed weight)
- **Automatic switch-off**

STANDARD I/O SECTION

- RS232/C bidirectional port for calibration and configuration from PC or printer.
- Infra-red port for remote control handle-bar (optional).

KEYBOARD FUNCTIONS

- Zeroing, Automatic tare, Manual tare, activation of the selected function, print, ON/OFF.

OPTIONS TO BE SPECIFIED WHEN ORDERING

- Parking brake.
- Remote control handle-bar.
- Special wheels available with price estimate.

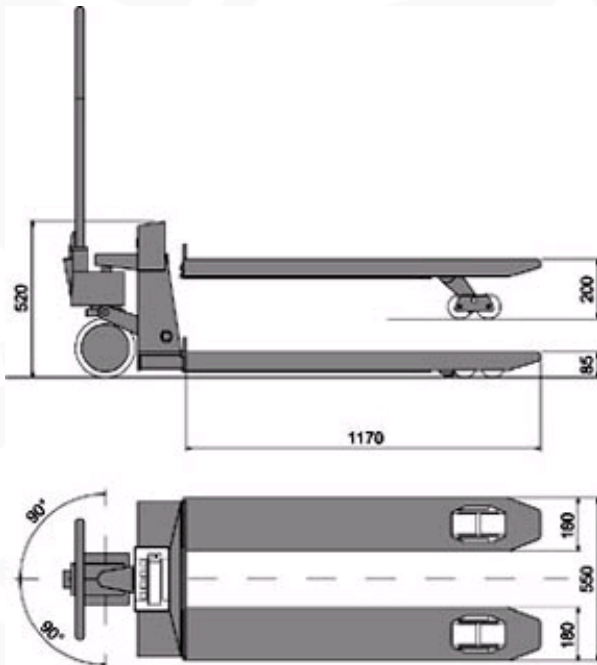

Dimensions in mm

Available versions

Code	Max Capacity kg	Division kg
TPWN	2000	1
TPWN3 NEW	500 / 1000 / 2000	0,5 / 1 / 2

Options only available at time of order

Code	Description
DFTL	Remote control for use up to 8m, configurable as a single tare key or four keys

TPWFRE Parking brake system with command pedal mounted on steering wheels

Accessories

Code	Description
TECMAN	Printed technical manual (free, if downloaded from the web) NET PRICE
UMAN	Printed user manual (free, if downloaded from the web) NET PRICE

Dini Argeo S.r.l.

Copyright 2002-2008 - All Rights Reserved -
[Privacy Policy](#)

www.diniargeo.com