

TPWI SERIES PALLET TRUCK SCALE



High performance stainless steel pallet truck scales with built-in multirange electronic weighing. The four IP68 stainless steel load cell weight detection guarantees the best accuracy in all work conditions. Reliable and suitable for one who needs to weigh accurately any type of product on a pallet. Available also CE-M APPROVED

MAIN FEATURES

- Maximum lifting capacity: 2000Kg.
- Accuracy +/- 0.1% of the capacity.
- Fork dimensions 1170 x 550 x 85 mm.
- Weighs about 135 kg.
- **Bearing structure entirely in extra thick STAINLESS steel.**
- **Lifting pump in STAINLESS steel.**
- Steering wheels and double loading rollers with a poliurethane coating.
- 4 IP68 stainless steel shear beam load cells.
- Weight indicator with **waterproof IP68 STAINLESS STEEL case**, easy to clean and resistant to harsh and corrosive environments; large 25mm high contrast LCD display, clearly visible also in poor lighting conditions, and membrane waterproof keypad, with 17 numerical/functional keys.
- Calibration and Set-Up configurable from keyboard or from PC with DINITOOLS.
- Power supply through built-in rechargeable battery.
- 50-hour approximate operating time or one month with the typical non continuous use, thanks to its auto switch-off function.
- Programmable auto power saving function.
- Low Battery Warning.
- Equipped with 230Vac 50 Hz battery charger (recharging time is about 8 hours).
- Bi-directional RS232/C port for connection to printer.
- Bi-directional RS232/C port for PC, radio modem, or portable terminal.
- IR input for managing the remote control

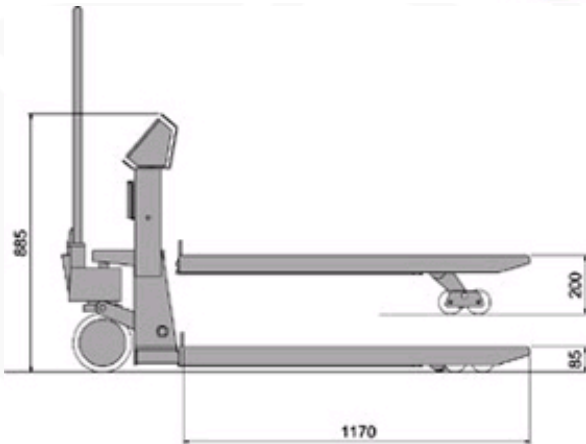

Dimensions in mm

SELECTABLE FUNCTIONS

- **High Resolution Weighing x 10**
- **Net/Gross or lb/kg conversion**
- **Accumulation**
- **Formula weighing**
- **+/- Checkweighing**
- **Percentage weighing**
- **Counting** (Max. resolution of 1.500.000 divisions)
- **In/Out weighing**
- **Hold and Peak**
- **Peer-to-peer** (up to 4 remote connectable indicators)
- **Set Point Control** (with optional interface)

OPTIONS ONLY AVAILABLE AT TIME OF ORDER

- Thermal printer / Modem radio option box
- WI-FI interface
- Alibi memory with time-date
- Time-Date
- 2 inputs + 2 outputs configurable on gross or net weight
- Swivel column
- Parking brake
- 680 mm fork width (ask for price estimate)
- Special fork length from 850 to 1500 mm (ask for price estimate)
- 3000 kg capacity (ask for price estimate)
- Special wheels available with price estimate

KEYBOARD AND PRINT FUNCTIONS

- **KEYBOARD:** Zeroing, Automatic tare, Print and/or data transmission command, activation of selected function. Presettable tare, ID1 code, ID2 code, 10 recallable tare values.
- **PRINTOUT:** configurable layout with: 3 header rows, net weight, gross weight, tare weight or weight totalized and total weigh, time/date, ticket number, weigh number.

Available versions

Code	Max Capacity kg	Division kg	CE-M Division kg
------	-----------------	-------------	------------------

TPW20I

500 / 1000 / 2000

0,2 / 0,5 / 1

--

TPW20IM 

1000 / 2000

--

0,5/1

Options only available at time of order

Code	Description
TPRXTP	Thermal printer for column mounting, ABS and Stainless Steel case, with door for protection from sprays and dust. IP65 protection. Speed > 50mm/sec. 203 dpi resolution, 24/40 columns, 58 mm paper width; 50 mm roll diameter.
DFCLK	Real Time Clock (Time/date)
DFIO	Module of 2 optoisolated digital inputs + 2 Photomosfet outputs usable as programmable weight threshold setpoints (not combinable with alibi memory ALMEM)
ALMEM	Alibi memory (fiscal memory) with time/date; max. 120.000 weighs
WIFIT	WI-FI interface for wireless connection (through access point) to the company computer system.

Accessories

Code	Description
UKPLUG	Power adapter from Schuko to BS1363.
TECMAN	Printed technical manual (free, if downloaded from the web) NET PRICE
UMAN	Printed user manual (free, if downloaded from the web) NET PRICE