

TPWA "ACTIVITY" SERIES PALLET TRUCK SCALE

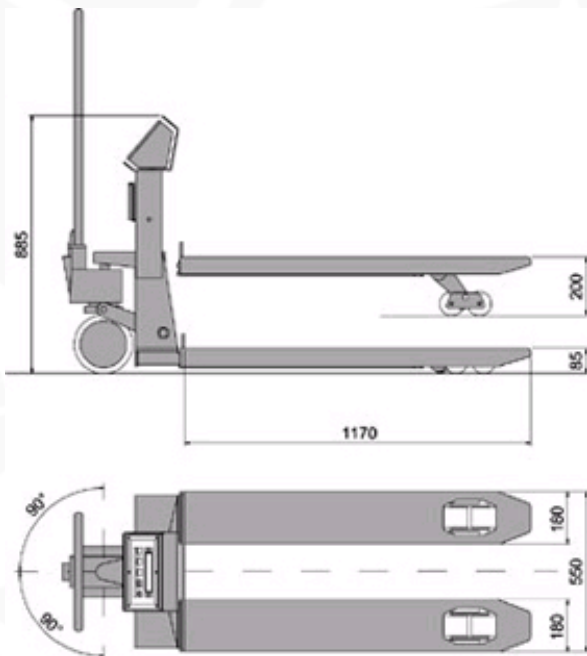

TPW20A with optional printer



Dimensions in mm

Pallet truck scales, with built-in electronic weighing integrated. The swivelling indicator guarantees the maximum reading ease. Reliable and suitable for one who needs to weigh accurately any type of product on a pallet.

Available also CE-M APPROVED.

MAIN FEATURES

- Maximum lifting capacity: 2000 kg.
- Accuracy: +/- 0.1% of the capacity.
- Fork dimensions 1170 x 550 x 85 mm.
- Weighs about 125 kg.
- Bearing structure in extra thick sheet steel and oven-fire painted interior construction.
- **Standard fitted swivelling column head.**
- Steering wheels and double loading rollers with a poliurethane coating.
- 4 shear-beam load cells.
- Indicator with easy to clean **ABS waterproof IP65** enclosure built to withstand humid and dusty environments; large LCD display 25-mm high contrast digits which are clearly visible even in poor lighting conditions; 5-key numerical/functional waterproof keyboard.
- Calibration and Set-Up configurable from keyboard or from PC with DINITOOLS.
- Power supply through built-in rechargeable battery.
- 50-hour approximate operating time or three months with the typical non continuous use, thanks to its auto switch-off function.
- Programmable auto power saving function.
- Low Battery Warning.
- Equipped with 230Vac 50 Hz battery charger (recharging time is about 8 hours).
- Bi-directional RS232/C port configurable for connection to printer.
- Bi-directional RS232/C serial output for radio modem, PC or portable terminal.
- IR input for managing remote control.

SELECTABLE FUNCTIONS

- **High Resolution Weighing x 10**
- **Net/Gross or lb/kg conversion**
- **Accumulation**
- **Formula weighing**
- **+/- Checkweighing**
- **Percentage weighing**
- **Counting** (Max. resolution of 1.500.000 divisions),
- **In/Out Truck weighing**
- **Hold and Peak**
- **Peer-to-peer** (up to 4 remote connectable indicators)
- **Set Point Control** (with optional interface)

OPTIONS ONLY AVAILABLE AT TIME OF ORDER

- Extractable rechargeable battery.
- Thermal/Virtual printer with Memory Card.
- Modem radio option box / WI-FI interface.
- Alibi memory with time-date
- Time-Date
- 2 inputs + 2 outputs configurable on gross or net weight.
- Stainless steel forks / Parking brake.
- 680 mm fork width (ask for price estimate).
- Special fork length from 850 to 1500 mm (ask for price estimate).
- 3000 kg capacity (ask for price estimate).
- Version with high resolution (ask for price estimate).
- Special wheels available with price estimate.

KEYBOARD FUNCTIONS AND PRINTOUT

- **KEYBOARD:** Zeroing, Automatic tare, Presetable tare, Print and/or data transmission command, Function command (totalization or counting).
- **PRINTOUT** with:
3 header rows, net weight, gross weight, tare weight or weight totalized and total weigh, time/date, ticket number, weigh nr.

Code	Max Capacity kg	Division kg	CE-M Division kg
TPW20A	500 / 1000 / 2000	0,2 / 0,5 / 1	
TPW20AM M	1000 / 2000		0,5 / 1

Options only available at time of order

Code	Description
TPWXFI	Pair of stainless steel forks.
TPRPL	Thermal printer with >50mm/sec. speed, 203 dpi resolution, 24/40 columns, 58 mm width; 50 mm roll diameter.
TPWLMMC	Virtual printer: allows to store on the memory card all the printable data, which may then be saved and processed through the PC; complet of memory card. Integrated in pallet truck column (not available with Backup battery kit)
TPWLMDP	Virtual printer and thermal printer integrated in pallet truck column (not available with Backup battery kit)
RFITR	Integrated radio interface for crane scale/pallet truck scale , complete of RS232 port. Max. functioning distance in appropriate conditions: 70m indoors, 150m outdoors. Up to 50 configurable channels (must be combined with another radio modem)
OBRFUSB	868MHz radio frequency module for PC with USB input, selfpowered, connectable to USB ports. Fitted with USB connection cable. Max. functioning distance in appropriate conditions: 70m indoor, 150m outdoor. 50 available channels, easily programmable from the PC.
DFCLK	Real Time Clock (Time/date)
OBRF232	868 MHz radio frequency module for PC with RS232 9-pole input, connectable to RS232 ports. Fitted with connection/power supply cable. Max. functioning distance in appropriate conditions: 70m indoors, 150m outdoors. 50 available channels, easily programmable from PC.
DFIO	Module of 2 optoisolated digital inputs + 2 Photomosfet outputs usable as programmable weight threshold setpoints (not combinable with alibi memory ALMEM)
ALMEM	Alibi memory (fiscal memory) with time/date; max. 120.000 weighs
WIFIT	WI-FI interface for wireless connection (through access point) to the company computer system.
TPWFRE	Parking brake system with command pedal mounted on steering wheels
TPWLBK	Extractable backup battery kit
TPWBKB	Additional rechargeable battery for Backup Battery Kit.
TPWLBKPT	Backup battery kit and thermal printer for TPW pallet truck scales

Accessories

Code	Description
UKPLUG	Power adapter from Schuko to BS1363.
TECMAN	Printed technical manual (free, if downloaded from the web) NET PRICE
UMAN	Printed user manual (free, if downloaded from the web) NET PRICE