

ET SERIES 4-CELL PLATFORMS

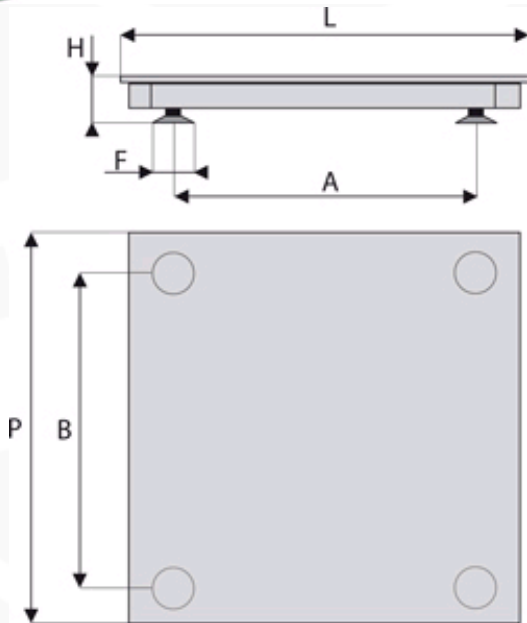

3000e + 3000e



Mod./Dim.	L	P	H	A	B	F
ETA	1000	1000	90	850	850	75
ETM	1000	1250	90	850	1100	75
ETB	1250	1250	90	1070	1070	75
ETD	1250	1500	110	1070	1320	75
ETE	1500	1500	110	1320	1320	75
ETF	1500	2000	130	1300	1800	75
ETG	1500	2000	150	1300	1800	100
ETH	1500	2500	180	1280	2280	100
ETL	2000	2500	180	1780	2280	100

dimensions in mm

Low profile electronic platforms with removable loading plate. Fitted with IP68 STAINLESS STEEL load cells. Suitable for creating scales and electronic weighing systems for all types of industrial and commercial applications. Standard version is with approved load cell.

MAIN FEATURES

- Fitted with 4 STAINLESS STEEL shear-beam approved load cells each with 350 Ohm input resistance and made according to OIML R60 standards with protection against dust and under water immersion according to IP68 standards.
- Steel tubular bearing structure, oven-fire painted in RAL 5007 blue; removable loading surface made in extra thick galvanised steel; inspectionable trapdoor housing the junction box.
- Adjustable, stainless steel shock-proof jointed feet and level. Up to 15 Vdc power supply.
- Junction box and wiring cables with sheathing according to IP67 standards, and screened 5m long 6-pin cable for connection to the indicator complete with connectors

OPTIONS ONLY AVAILABLE AT TIME OF ORDER

- Connection to the indicator and calibration with CE-M 3000e single range or 3000e+3000e dual range approval.
- Stainless steel surface.
- High resolution models for internal factory use.

OPTIONS FOR ATEX VERSION

- CCATEX: ATEX certificate for each load cell.
- JB4QA: ATEX certified junction box.
- DCATEXMECH: Declaration of conformity of the whole system composed of PLATFORM + JUNCTION BOX + LOAD CELLS (only if the platform is ordered without the weight indicator; otherwise, refer to the certifications available for the indicator to which it will be connected).

ACCESSORIES

- Indicator support column.
- Frames for flush floor installation.
- Access ramps.
- Special sizes and capacities upon estimate.

Available versions

Code	Dimensions (LxPxH)	Max Capacity kg	Standard Division g	CE-M Division g (*)	CE-M2 Division g (*)	HR Division g (*)
ETA3	1000x1000x90	300	50	100	--	20
ETA6	1000x1000x90	600	100	200	100-200	50
ETA15	1000x1000x90	1500	200	500	200-500	100
ETM3	1000x1250x90	300	50	100	--	20
ETM6	1000x1250x90	600	100	200	100-200	50
ETM15	1000x1250x90	1500	200	500	200-500	100
ETB3	1250x1250x90	300	50	100	--	20
ETB6	1250x1250x90	600	100	200	100-200	50
ETB15	1250x1250x90	1500	200	500	200-500	100
ETD6	1250x1500x110	600	100	200	100-200	50

ETD15	1250x1500x110	1500	200	500	200-500	100
ETD30	1250x1500x110	3000	500	1000	500-1000	200
ETE6	1500x1500x110	600	100	200	100-200	50
ETE15	1500x1500x110	1500	200	500	200-500	100
ETE30	1500x1500x110	3000	500	1000	500-1000	200
ETF6	1500x2000x130	600	100	200	100-200	50
ETF15	1500x2000x130	1500	200	500	200-500	100
ETF30	1500x2000x130	3000	500	1000	500-1000	200
ETG60	1500x2000x150	6000	1000	2000	1000-2000	500
ETH30	1500x2500x180	3000	500	1000	--	200
ETH60	1500x2500x180	6000	1000	2000	1000-2000	500
ETH100	1500x2500x180	10000	2000	5000	2000-5000	1000
ETL30	2000x2500x180	3000	500	1000	--	200
ETL60	2000x2500x180	6000	1000	2000	1000-2000	500
ETL100	2000x2500x180	10000	2000	5000	2000-5000	1000

(*) These divisions are obtainable only with the relative options

Options only available at time of order

Code	Description
ECEM1B	CE-M 3000e initial stamping for class III or IIII scales with capacity from 31 to 1500 kg
ECEM2B	CE-M 2x3000e initial stamping for class III or IIII scales with capacity from 31 to 1500 kg
ECEM1C	CE-M 3000e initial stamping for class III or IIII scales with capacity from 1501 to 6000 kg
ECEM2C	CE-M 2x3000e initial stamping for class III or IIII scales with capacity from 1501 to 6000 kg
ECEM1D	CE-M 3000e initial stamping for class III or IIII scales with capacity from 6001 to 15000 kg
ECEM2D	CE-M 2x3000e initial stamping for class III or IIII scales with capacity from 6001 to 15000 kg
ETHR	High resolution (HR) model
CCATEX	ATEX certificate for each load cell for the following categories: II 1G EExia IIC T6 (Ta -20÷+40°C) TX (Ta -20÷+65°C) II 1D tD A20 TX°C (Ta -20÷+40°C) TX°C (Ta -20÷+65°C).
JB4QA	Junction and equalisation box with 4 inputs, for ATEX environments, in IP67 ABS. Protection degree: II 2G EEx ib IIC T6 for gases. II 2D Ex tD A21 IP65 T115°C for dust.
DCATEXMECH	DECLARATION OF ATEX CONFORMITY OF WHOLE Ex II 2GD SYSTEM with relative WHOLE SYSTEM LABEL, for mechanical structure with ATEX load cells (each cell must be certified with CCATEX option).
ETAPI	AISI 304 stainless steel 1000x1000x5 mm surface option for ETA
ETMPI	AISI 304 stainless steel 1000x1250x5 mm surface option for ETM
ETBPI	AISI 304 stainless steel 1250x1250x5 mm surface option for ETB
ETDPI	AISI 304 stainless steel 1250x1500x5 mm surface option for ETD
ETEPI	AISI 304 stainless steel 1500x1500x5 mm surface option for ETE
ETFPI	AISI 304 stainless steel 1500x2000x5 mm surface option for ETF
ETHPI	AISI 304 stainless steel 1500x2500x5 mm surface option for ETH

Accessories

Code	Description
CSP	Floor indicator support stand h=1080 mm
ETATF	Frame for flush floor installation 1000x1000 mm
ETMTF	Frame for flush floor installation 1000x1250 mm
ETBTF	Frame for flush floor installation 1250x1250 mm
ETDTF	Frame for flush floor installation 1250x1500 mm
ETETF	Frame for flush floor installation 1500x1500 mm
ETFTF	Frame for flush floor installation 1500x2000 mm
ETGTF	Frame for flush floor installation 1500x2000 mm
ETHTF	Frame for flush floor installation 1500x2500 mm
ETLTF	Frame for flush floor installation 2000x2500 mm
ETAR	Access ramp 1000x900 mm (lxp) for 1000x1000 and 1000x1250 mm platforms
ETBR	Access ramp 1250x900 (lxp) for 1250x1250 mm platform
ETDR	Access ramp 1250x1100 (lxp) for 1250x1500 mm platform
ETER	Access ramp 1500x1100 (lxp) for 1500x1500 mm platform
ETPFI	<u>STAINLESS STEEL plates for installing platforms</u> (ELC, ETA, ELA, ETM, ETB, ELB, ETD, ELD, ETE, ELE, and ETF series) on the floor (set of 4)
ETPFIM20	<u>STAINLESS STEEL plates for installing platforms</u> (ETG, ETH and ETL series) on the floor (set of 4)

NOTES

ALWAYS MAKE SURE THAT THE RESULTING INCLINATION OF THE RAMP IS COMPATIBLE WITH THE SPECIFICATIONS OF THE VEHICLES USED FOR LOADING AND UNLOADING.
ALSO PROTECT THE PLATFORM SIDES BY MOUNTING, WHERE NECESSARY, APPROPRIATE ANGULAR PROTECTION PIECES (GUARD RAILS)

