

# ELW SERIES ELECTRIC PALLET TRUCK SCALE

**Electric pallet truck scales, with built-in electronic weighing, which are reliable, easy to use, suitable for harsh work conditions, and essential for one who needs to weigh accurately but save time also.**  
**Available also CE-M APPROVED**



## WEIGHING SYSTEM FEATURES

- Maximum lifting capacity: 2000kg
- Accuracy: +/- 0.05% of the capacity
- Bearing structure in extra thick sheet steel with oven-fire painted interior construction.
- Wheels in Vulkolan
- 4 shear-beam load cells and connections in IP67.
- Indicator with 17-key numerical/functional waterproof keyboard. Large LCD display with 6 25-mm high contrast digits with icons for indicating active functions. Easy to clean **Waterproof IP65 ABS** case resistant to harsh and corrosive environments.
- Calibration and Set-Up parameters configurable from keyboard.
- Power supply through built-in rechargeable battery
- 40-hour approximate operating time
- Programmable auto power saving function
- Low Battery Warning
- Equipped with 230Vac 50 Hz battery charger (approximate 8-hour recharging time)
- Bi-directional RS232/C port for connection to printer
- Bi-directional RS232/C serial output for radio modem, PC or portable terminal

## SELECTABLE FUNCTIONS

- **High Resolution Weighing x 10**
- **Net/Gross or lb/kg conversion**
- **Accumulation**
- **Formula weighing**
- **+/- Checkweighing**
- **Percentage weighing**
- **Counting** (Max. resolution of 1.500.000 divisions)
- **In/Out Truck weighing**
- **Hold and Peak**
- **Peer-to-peer** (up to 4 remote connectable indicators)
- **Set Point Control** (with optional interface)

## KEYBOARD FUNCTIONS

- Zeroing, Automatic tare, Print and/or data transmission command, Function command (totalization or counting).
- Presetable tare, ID1 code, ID2 code, 10 recallable tare values

## ELECTRIC & MECHANICAL CHARACTERISTICS OF PALLET TRUCK

- Barycenter distance 600 mm
- Fork height variation range: from 90 mm with forks down up to a maximum 210 mm lifting from ground.
- Settable lowering speed
- Maximum incline surpassable by 10% with load, 18% without load
- Electromagnetic service and parking brakes
- Armored battery 24 VDC 180 Ah fitted with battery charger
- Electric motor power traction 1.2 Kw; lifting 2 Kw

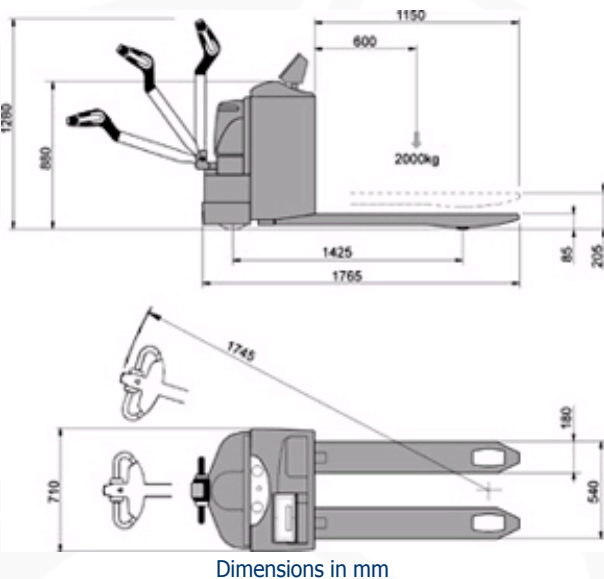

## OPTIONS ONLY AVAILABLE AT TIME OF ORDER

- Thermal printer integrated to the column
- Modem radio option box
- WI-FI interface
- Alibi memory with time/date
- Time/Date
- 2 inputs + 2 outputs configurable on gross or net weight

## Available versions

Code

Max Capacity kg

CE-M Division kg

Division kg

ELW20D	600 / 1500 / 2000	--	0,2 / 0,5 / 1
ELW6M	600	0,2	
ELW15M	1500	0,5	--
ELW20M	2000	1	

### Options only available at time of order

Code	Description
OBTPRP	<b>Attached</b> thermal printer in ABS option box for ...XP indicators with 50mm/sec speed, 203 dpi resolution, 24/40 columns, 58 mm paper width; 50 mm Roll diameter.
OBMDP	<b>Attached</b> thermal printer and memory data printer (fitted with a memory card) in ABS option box for ...XP indicators
OBRF	External radio interface, fitted in ABS case with IP65 protection and a 3-metre cable, for <b>weight indicator/repeater</b> . Max. functioning distance in adequate conditions: 70m indoors, 150m outdoors. Up to 50 configurable channels (OBRF must be combined with another radio modem).
OBRFUSB	868MHz radio frequency module for PC with USB input, selfpowered, connectable to USB ports. Fitted with USB connection cable. Max. functioning distance in appropriate conditions: 70m indoor, 150m outdoor. 50 available channels, easily programmable from the PC.
OBRF232	868 MHz radio frequency module for PC with RS232 9-pole input, connectable to RS232 ports. Fitted with connection/power supply cable. Max. functioning distance in appropriate conditions: 70m indoors, 150m outdoors. 50 available channels, easily programmable from PC.
DFCLK	Real Time Clock (Time/date)
DFIO	Module of 2 optoisolated digital inputs + 2 Photomosfet outputs usable as programmable weight threshold setpoints (not combinable with alibi memory ALMEM)
ALMEM	Alibi memory (fiscal memory) with time/date; max. 120.000 weighs
WIFIT	WI-FI interface for wireless connection (through access point) to the company computer system.

### Accessories

Code	Description
UKPLUG	Power adapter from Schuko to BS1363.
TECMAN	Printed technical manual (free, if downloaded from the web) NET PRICE
UMAN	Printed user manual (free, if downloaded from the web) NET PRICE

Example of R.F. data communication between the ELW and a PC.

Note: the minimum height of the R.F.module on wall is 2m if the maximum distance is 50m, otherwise, it should be 3m if greater than 50m.

