



11) BELT DIRECTION:

**s** (from right to left)

**d** (from left to right)

12) TYPE OF WEIGHING SYSTEM:

FOR INTERNAL USE

FOR LEGAL FOR TRADE USE

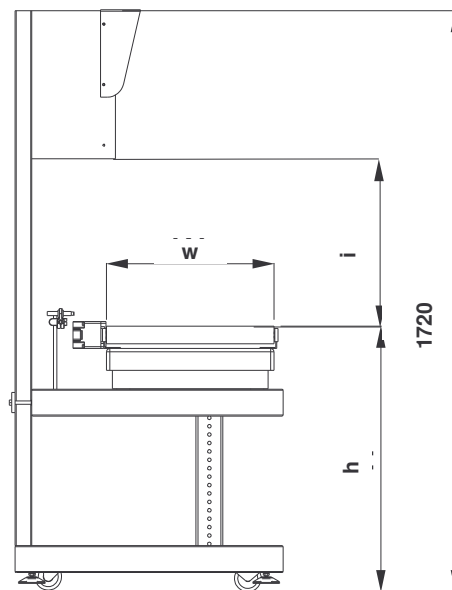
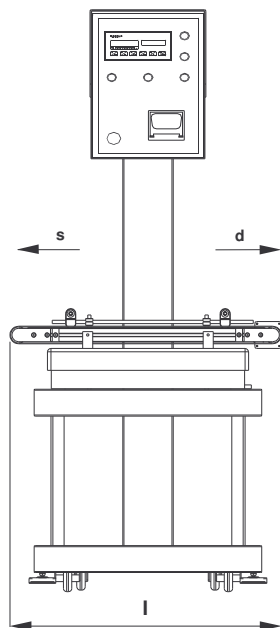

**w**: standard size = 500mm

**l** : standard size = 800mm

**h**: standard sizes = min 450mm; MAX 850mm

Possibility of subsequent adjustment when in use of up to  $\pm 50$ mm, in steps of 25mm.

**i**: standard sizes = min 430mm; MAX 830mm (maximum height of pack, depending on h)

**h + i** : 1280 mm

**Belt speed**: from 1 to 25m/min, adjustable.

**Standard capacities:**

6kg / 2g	(6kg / 1 g in H.R.)
15kg / 5g	(15kg / 2 g in H.R.)
30kg / 10g	(30kg / 5 g in H.R.)

**!! IMPORTANT !!**

**The feasibility of the order will be verified by our technicians once this form, completely filled in, is received.**

DINI AR GEO  
Sede / Head Office

Via della Fisica, 20  
41042 Spezzano di Fiorano (MO) - Italy  
Tel. +39-0536-843418  
Fax +39-0536-843521  
[info@diniargeo.com](mailto:info@diniargeo.com)

SERVICE ASSISTANCE  
Italy

Via dell'Elettronica, 18  
41042 Spezzano di Fiorano (MO) - Italy  
Tel. +39-0536-921784  
Fax +39-0536-926654  
[service@diniargeo.com](mailto:service@diniargeo.com)

DINI AR GEO GMBH  
Sinsheim - GERMANY  
[info.de@diniargeo.com](mailto:info.de@diniargeo.com)

DINI AR GEO FRANCE SARL  
Nogent-sur-Marne - FRANCE  
[info.fr@diniargeo.com](mailto:info.fr@diniargeo.com)

DINI AR GEO WEIGHBRIDGES  
Calto (RO) - ITALY  
[sales@diniargeo.com](mailto:sales@diniargeo.com)

DINI AR GEO SHANGHAI LTD  
Shanghai - CHINA  
[info.cn@diniargeo.com](mailto:info.cn@diniargeo.com)